

# Low Power, 1kHz to 20MHz Resistor Set SOT-23 Oscillator

January 2002

## FEATURES

- One External Resistor Sets the Frequency
- 1kHz to 20MHz Frequency Range
- 500µA Typical Supply Current,  $V_S = 3V$ , 3MHz
- Frequency Error  $\leq 1.5\%$  Max 5kHz to 10MHz ( $T_A = 25^\circ C$ )
- Frequency Error  $\leq 2\%$  Max 5kHz to 10MHz ( $T_A = 0^\circ C$  to  $70^\circ C$ )
- $\pm 40$ ppm/ $^\circ C$  Temperature Stability
- 0.04%/V Supply Stability
- 50%  $\pm 1\%$  Duty Cycle 1kHz to 2MHz
- 50%  $\pm 5\%$  Duty Cycle 2MHz to 10MHz
- Fast Start-Up Time:  $< 1.5$ ms
- 100Ω CMOS Output Driver
- Operates from a Single 2.7V to 5.5V Supply
- Low Profile (1mm) ThinSOT™ Package

## APPLICATIONS

- Portable and Battery-Powered Equipment
- PDAs
- Cell Phones
- Low Cost Precision Oscillator
- Charge Pump Driver
- Switching Power Supply Clock Reference
- Clocking Switched Capacitor Filters
- Fixed Crystal Oscillator Replacement
- Ceramic Oscillator Replacement

## DESCRIPTION

The LTC®6900 is a precision, low power oscillator that is easy to use and occupies very little PC board space. The oscillator frequency is programmed by a single external resistor ( $R_{SET}$ ). The LTC6900 has been designed for high accuracy operation ( $\leq 1.5\%$  frequency error) without the need for external trim components.

The LTC6900 operates with a single 2.7V to 5.5V power supply and provides a rail-to-rail, 50% duty cycle square wave output. The CMOS output driver ensures fast rise/fall times and rail-to-rail switching. The frequency-setting resistor can vary from 10kΩ to 2MΩ to select a master oscillator frequency between 100kHz and 20MHz (5V supply). The three-state DIV input determines whether the master clock is divided by 1, 10 or 100 before driving the output, providing three frequency ranges spanning 1kHz to 20MHz (5V supply). The LTC6900 features a proprietary feedback loop that linearizes the relationship between  $R_{SET}$  and frequency, eliminating the need for tables to calculate frequency. The oscillator can be easily programmed using the simple formula outlined below:

$$f_{OSC} = 10MHz \cdot \left( \frac{20k}{N \cdot R_{SET}} \right), N = \begin{cases} 100, & \text{DIV Pin} = V^+ \\ 10, & \text{DIV Pin} = \text{Open} \\ 1, & \text{DIV Pin} = \text{GND} \end{cases}$$

 LTC and LT are registered trademarks of Linear Technology Corporation. ThinSOT is a trademark of Linear Technology Corporation.

## TYPICAL APPLICATION

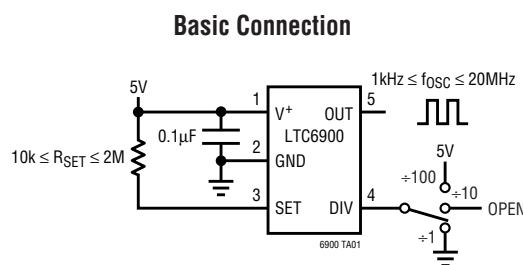

SOT-23 Actual Size



**$R_{SET}$  vs Desired Output Frequency**

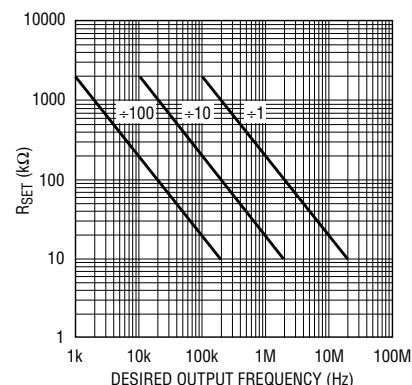

6900 F02

## ABSOLUTE MAXIMUM RATINGS

(Note 1)

Supply Voltage ( $V^+$ ) to GND .....	-0.3V to 6V
DIV to GND .....	-0.3V to ( $V^+ + 0.3V$ )
SET to GND .....	-0.3V to ( $V^+ + 0.3V$ )
Operating Temperature Range	
LTC6900C .....	0°C to 70°C
LTC6900I .....	-40°C to 85°C
Storage Temperature Range .....	-65°C to 150°C
Lead Temperature (Soldering, 10 sec) .....	300°C

## PACKAGE/ORDER INFORMATION

	ORDER PART NUMBER
	LTC6900CS5 LTC6900IS5
	S5 PART MARKING
	LTZM

Consult LTC Marketing for parts specified with wider operating temperature ranges.

## ELECTRICAL CHARACTERISTICS

The ● denotes the specifications which apply over the full operating temperature range, otherwise specifications are at  $T_A = 25^\circ\text{C}$ .  $V^+ = 2.7\text{V}$  to  $5.5\text{V}$ ,  $R_L = 5\text{k}\Omega$ ,  $C_L = 5\text{pF}$ , unless otherwise noted. All voltages are with respect to GND.

SYMBOL	PARAMETER	CONDITIONS		MIN	TYP	MAX	UNITS				
$\Delta f$	Frequency Accuracy (Notes 2, 3)	$V^+ = 5\text{V}$	$5\text{kHz} \leq f \leq 10\text{MHz}$		$\pm 0.5$	$\pm 1.5$	%				
			$5\text{kHz} \leq f \leq 10\text{MHz}$ , LTC6900C ●			$\pm 2.0$	%				
			$5\text{kHz} \leq f \leq 10\text{MHz}$ , LTC6900I ●			$\pm 2.5$	%				
		$V^+ = 3\text{V}$	$1\text{kHz} \leq f \leq 5\text{kHz}$		$\pm 2$		%				
			$10\text{MHz} \leq f \leq 20\text{MHz}$		$\pm 2$		%				
			$5\text{kHz} \leq f \leq 10\text{MHz}$		$\pm 0.5$	$\pm 1.5$	%				
$R_{\text{SET}}$	Frequency-Setting Resistor Range	$ \Delta f  < 1.5\%$	$V^+ = 5\text{V}$		20	400	$\text{k}\Omega$				
					20	400	$\text{k}\Omega$				
				$V^+ = 3\text{V}$							
			$V^+ = 3\text{V}$	$5\text{kHz} \leq f \leq 10\text{MHz}$		$\pm 0.5$	$\pm 1.5$	%			
				$5\text{kHz} \leq f \leq 10\text{MHz}$ , LTC6900C ●			$\pm 2.0$	%			
				$5\text{kHz} \leq f \leq 10\text{MHz}$ , LTC6900I ●			$\pm 2.5$	%			
$\Delta f/\Delta T$	Freq Drift Over Temp (Note 3)	$R_{\text{SET}} = 63.2\text{k}$		●	$\pm 0.004$		$\%/^\circ\text{C}$				
			$\Delta f/\Delta V$	Freq Drift Over Supply (Note 3)	$V^+ = 3\text{V}$ to $5\text{V}$ , $R_{\text{SET}} = 63.2\text{k}$	●	0.04	0.1	$\%/V$		
						Timing Jitter (Note 4)	Pin 4 = $V^+$ , $20\text{k} \leq R_{\text{SET}} \leq 400\text{k}$		0.1		%
							Pin 4 = Open, $20\text{k} \leq R_{\text{SET}} \leq 400\text{k}$		0.2		%
							Pin 4 = 0V, $20\text{k} \leq R_{\text{SET}} \leq 400\text{k}$		0.6		%
						Long-Term Stability of Output Frequency			300		$\text{ppm}/\sqrt{\text{kHr}}$
Duty Cycle (Note 7)	Pin 4 = $V^+$ or Open (DIV Either by 100 or 10)	●				49	50	51	%		
		●	45	50	55	%					
$V^+$	Operating Supply Range		●	2.7	5.5	V					
		$I_S$	Power Supply Current	$R_{\text{SET}} = 400\text{k}$ , Pin 4 = $V^+$ , $R_L = \infty$	$V^+ = 5\text{V}$	●	0.32	0.42	$\text{mA}$		
					$V^+ = 3\text{V}$	●	0.29	0.38	$\text{mA}$		
				$R_{\text{SET}} = 20\text{k}$ , Pin 4 = 0V, $R_L = \infty$	$V^+ = 5\text{V}$	●	0.92	1.20	$\text{mA}$		
$V^+ = 3\text{V}$	●				0.68	0.86	$\text{mA}$				
$V_{\text{IH}}$	High Level DIV Input Voltage		●	$V^+ - 0.4$		V					
$V_{\text{IL}}$	Low Level DIV Input Voltage		●		0.5	V					
$I_{\text{DIV}}$	DIV Input Current (Note 5)	Pin 4 = $V^+$	$V^+ = 5\text{V}$	●	2	4	$\mu\text{A}$				
		Pin 4 = 0V	$V^+ = 5\text{V}$	●	-4	-2	$\mu\text{A}$				

**ELECTRICAL CHARACTERISTICS** The ● denotes the specifications which apply over the full operating temperature range, otherwise specifications are at  $T_A = 25^\circ\text{C}$ .  $V^+ = 2.7\text{V}$  to  $5.5\text{V}$ ,  $R_L = 5\text{k}$ ,  $C_L = 5\text{pF}$ , Pin 4 =  $V^+$  unless otherwise noted. All voltages are with respect to GND.

SYMBOL	PARAMETER	CONDITIONS		MIN	TYP	MAX	UNITS	
$V_{OH}$	High Level Output Voltage (Note 5)	$V^+ = 5\text{V}$	$I_{OH} = -1\text{mA}$	●	4.8	4.95	V	
			$I_{OH} = -4\text{mA}$	●	4.5	4.8	V	
		$V^+ = 3\text{V}$	$I_{OH} = -1\text{mA}$	●	2.7	2.9	V	
			$I_{OH} = -4\text{mA}$	●	2.2	2.6	V	
$V_{OL}$	Low Level Output Voltage (Note 5)	$V^+ = 5\text{V}$	$I_{OL} = 1\text{mA}$	●		0.05	0.15	V
			$I_{OL} = 4\text{mA}$	●		0.2	0.4	V
		$V^+ = 3\text{V}$	$I_{OL} = 1\text{mA}$	●		0.1	0.3	V
			$I_{OL} = 4\text{mA}$	●		0.4	0.7	V
$t_r$	OUT Rise Time (Note 6)	$V^+ = 5\text{V}$	Pin 4 = $V^+$ or Floating, $R_L = \infty$			14	ns	
			Pin 4 = $0\text{V}$ , $R_L = \infty$			7	ns	
		$V^+ = 3\text{V}$	Pin 4 = $V^+$ or Floating, $R_L = \infty$			19	ns	
			Pin 4 = $0\text{V}$ , $R_L = \infty$			11	ns	
$t_f$	OUT Fall Time (Note 6)	$V^+ = 5\text{V}$	Pin 4 = $V^+$ or Floating, $R_L = \infty$			13	ns	
			Pin 4 = $0\text{V}$ , $R_L = \infty$			6	ns	
		$V^+ = 3\text{V}$	Pin 4 = $V^+$ or Floating, $R_L = \infty$			19	ns	
			Pin 4 = $0\text{V}$ , $R_L = \infty$			10	ns	

**Note 1:** Absolute Maximum Ratings are those values beyond which the life of the device may be impaired.

**Note 2:** Frequencies near 100kHz and 1MHz may be generated using two different values of  $R_{SET}$  (see the Table 1 in the Applications Information section). For these frequencies, the error is specified under the following assumption:  $20\text{k} < R_{SET} \leq 200\text{k}$ .

**Note 3:** Frequency accuracy is defined as the deviation from the  $f_{OSC}$  equation.

**Note 4:** Jitter is the ratio of the peak-to-peak distribution of the period to the mean of the period. This specification is based on characterization and is not 100% tested.

**Note 5:** To conform with the Logic IC Standard convention, current out of a pin is arbitrarily given as a negative value.

**Note 6:** Output rise and fall times are measured between the 10% and 90% power supply levels. These specifications are based on characterization.

**Note 7:** Guaranteed by 5V test.

**PIN FUNCTIONS**

**V<sup>+</sup> (Pin 1):** Voltage Supply ( $2.7V \leq V^+ \leq 5.5V$ ). This supply must be kept free from noise and ripple. It should be bypassed directly to a ground plane with a 0.1μF capacitor.

**GND (Pin 2):** Ground. Should be tied to a ground plane for best performance.

**SET (Pin 3):** Frequency-Setting Resistor Input. The value of the resistor connected between this pin and V<sup>+</sup> determines the oscillator frequency. The voltage on this pin is held by the LTC6900 to approximately 1.1V below the V<sup>+</sup> voltage. For best performance, use a precision metal film resistor with a value between 10kΩ and 2MΩ and limit the capacitance on this pin to less than 10pF.

**DIV (Pin 4):** Divider-Setting Input. This three-state input selects among three divider settings, determining the value of N in the frequency equation. Pin 4 should be tied to GND for the ÷1 setting, the highest frequency range.

Floating Pin 4 divides the master oscillator by 10. Pin 4 should be tied to V<sup>+</sup> for the ÷100 setting, the lowest frequency range. To detect a floating DIV pin, the LTC6900 attempts to pull the pin toward midsupply. Therefore, driving the DIV pin high requires sourcing approximately 2μA. Likewise, driving DIV low requires sinking 2μA. When Pin 4 is floated, it should be bypassed by a 1nF capacitor to ground or it should be surrounded by a ground shield to prevent excessive coupling from other PCB traces.

**OUT (Pin 5):** Oscillator Output. This pin can drive 5kΩ and/or 10pF loads. Larger loads may cause inaccuracies due to supply bounce at high frequencies. Voltage transients above or below the LTC6900 power supplies will not cause latchup if the current into/out of the OUT pin is limited to 50mA.

**BLOCK DIAGRAM**

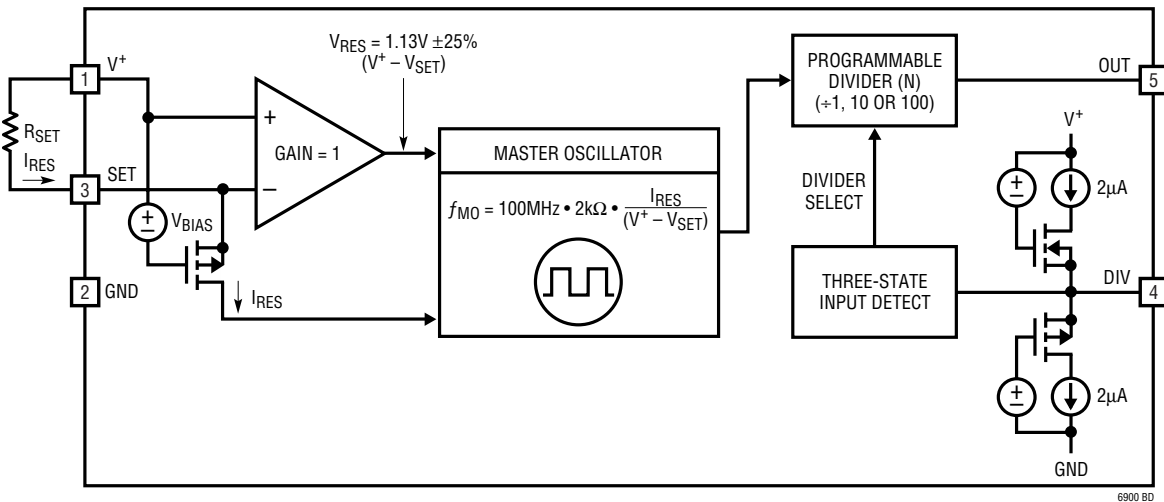

## THEORY OF OPERATION

As shown in the Block Diagram, the LTC6900's master oscillator is controlled by the ratio of the voltage between the  $V^+$  and SET pins and the current entering the SET pin ( $I_{RES}$ ). The voltage on the SET pin is forced to approximately 1.1V below  $V^+$  by the PMOS transistor and its gate bias voltage. This voltage is accurate to  $\pm 7\%$  at a particular input current and supply voltage (see Figure 1).

A resistor  $R_{SET}$ , connected between the  $V^+$  and SET pins, "locks together" the voltage ( $V^+ - V_{SET}$ ) and current,  $I_{RES}$ , variation. This provides the LTC6900's high precision. The master oscillation frequency reduces to:

$$f_{MO} = 10\text{MHz} \cdot \left( \frac{20\text{k}\Omega}{R_{SET}} \right)$$

The LTC6900 is optimized for use with resistors between 10k and 2M, corresponding to master oscillator frequencies between 100kHz and 20MHz.

To extend the output frequency range, the master oscillator signal may be divided by 1, 10 or 100 before driving OUT (Pin 5). The divide-by value is determined by the state of the DIV input (Pin 4). Tie DIV to GND or drive it below

0.5V to select  $\div 1$ . This is the highest frequency range, with the master output frequency passed directly to OUT. The DIV pin may be floated or driven to midsupply to select  $\div 10$ , the intermediate frequency range. The lowest frequency range,  $\div 100$ , is selected by tying DIV to  $V^+$  or driving it to within 0.4V of  $V^+$ . Figure 2 shows the relationship between  $R_{SET}$ , divider setting and output frequency, including the overlapping frequency ranges near 100kHz and 1MHz.

The CMOS output driver has an on resistance that is typically less than 100 $\Omega$ . In the  $\div 1$  (high frequency) mode, the rise and fall times are typically 7ns with a 5V supply and 11ns with a 3V supply. These times maintain a clean square wave at 10MHz (20MHz at 5V supply). In the  $\div 10$  and  $\div 100$  modes, where the output frequency is much lower, slew rate control circuitry in the output driver increases the rise/fall times to typically 14ns for a 5V supply and 19ns for a 3V supply. The reduced slew rate lowers EMI (electromagnetic interference) and supply bounce.

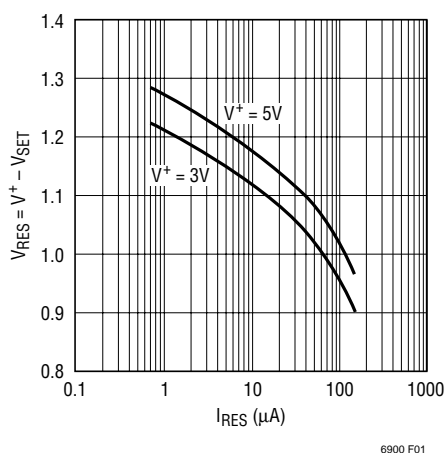

Figure 1.  $V^+ - V_{SET}$  Variation with  $I_{RES}$

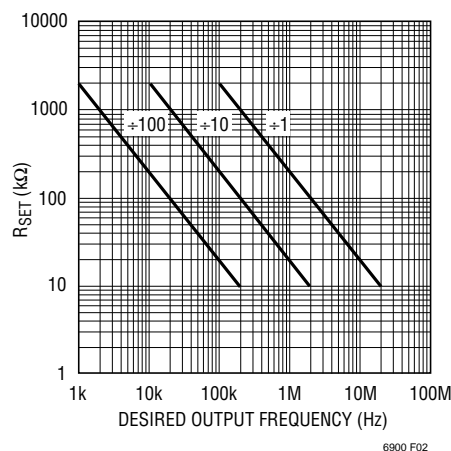

Figure 2.  $R_{SET}$  vs Desired Output Frequency

## APPLICATIONS INFORMATION

### SELECTING THE DIVIDER SETTING AND RESISTOR

The LTC6900’s master oscillator has a frequency range spanning 0.1MHz to 20MHz. However, accuracy may suffer if the master oscillator is operated at greater than 10MHz with a supply voltage lower than 4V. A programmable divider extends the frequency range to greater than three decades. Table 1 describes the recommended frequencies for each divider setting. Note that the ranges overlap; at some frequencies there are two divider/resistor combinations that result in the desired frequency.

In general, any given oscillator frequency ( $f_{OSC}$ ) should be obtained using the lowest master oscillator frequency. Lower master oscillator frequencies use less power and are more accurate. For instance,  $f_{OSC} = 100\text{kHz}$  can be obtained by either  $R_{SET} = 20\text{k}$ ,  $N = 100$ , master oscillator = 10MHz or  $R_{SET} = 200\text{k}$ ,  $N = 10$ , master oscillator = 1MHz. The  $R_{SET} = 200\text{k}$  is preferred for lower power and better accuracy.

**Table 1. Frequency Range vs Divider Setting**

DIVIDER SETTING	FREQUENCY RANGE
$\div 1 \Rightarrow$ DIV (Pin 4) = GND	$> 500\text{kHz}^*$
$\div 10 \Rightarrow$ DIV (Pin 4) = Floating	50kHz to 1MHz
$\div 100 \Rightarrow$ DIV (Pin 4) = $V^+$	$< 100\text{kHz}$

\*At master oscillator frequencies greater than 10MHz ( $R_{SET} < 20\text{k}\Omega$ ), the LTC6900 may suffer reduced accuracy with a supply voltage less than 4V.

After choosing the proper divider setting, determine the correct frequency-setting resistor. Because of the linear correspondence between oscillation period and resistance, a simple equation relates resistance with frequency.

$$R_{SET} = 20\text{k} \cdot \left( \frac{10\text{MHz}}{N \cdot f_{OSC}} \right), N = \begin{cases} 100 \\ 10 \\ 1 \end{cases}$$

$$(R_{SETMIN} = 10\text{k}, R_{SETMAX} = 2\text{M})$$

Any resistor,  $R_{SET}$ , tolerance adds to the inaccuracy of the oscillator,  $f_{OSC}$ .

### ALTERNATIVE METHODS OF SETTING THE OUTPUT FREQUENCY OF THE LTC6900

The oscillator may be programmed by any method that sources a current into the SET pin (Pin 3). The circuit in Figure 3 sets the oscillator frequency using a programmable current source and in the expression for  $f_{OSC}$ , the resistor  $R_{SET}$  is replaced by the ratio of  $1.1\text{V}/I_{CONTROL}$ . As already explained in the “Theory of Operation,” the voltage difference between  $V^+$  and SET is approximately 1.1V, therefore, the Figure 3 circuit is less accurate than if a resistor controls the oscillator frequency.

Figure 4 shows the LTC6900 configured as a VCO. A voltage source is connected in series with an external 20k resistor. The output frequency,  $f_{OSC}$ , will vary with  $V_{CONTROL}$ , that is the voltage source connected between  $V^+$  and the SET pin. Again, this circuit decouples the relationship between the input current and the voltage between  $V^+$  and SET; the frequency accuracy will be degraded. The oscillator frequency, however, will monotonically increase with decreasing  $V_{CONTROL}$ .

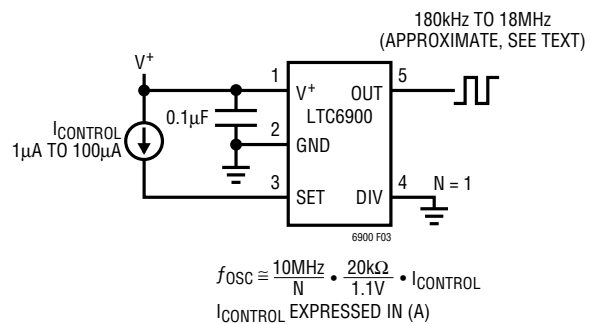

**Figure 3. Current Controlled Oscillator**

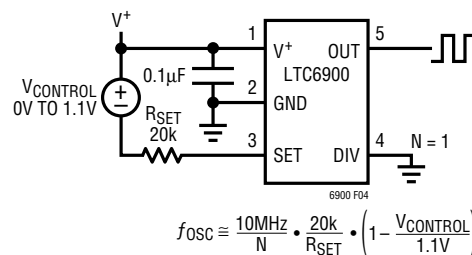

**Figure 4. Voltage Controlled Oscillator**

## APPLICATIONS INFORMATION

### POWER SUPPLY REJECTION

#### Low Frequency Supply Rejection (Voltage Coefficient)

Figure 5 shows the output frequency sensitivity to power supply voltage at several different temperatures. The LTC6900 has a conservative guaranteed voltage coefficient of 0.1%/V but, as Figure 5 shows, the typical supply sensitivity is lower.

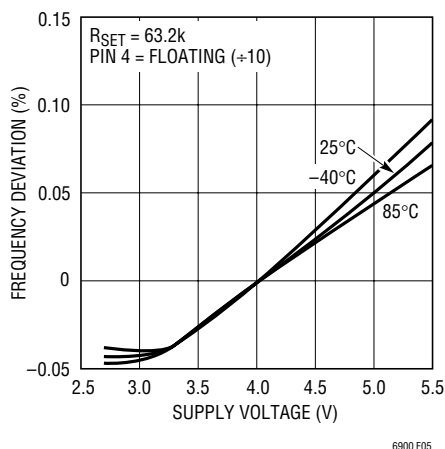

Figure 5. Supply Sensitivity

#### High Frequency Power Supply Rejection

The accuracy of the LTC6900 may be affected when its power supply generates significant noise with frequency contents in the vicinity of the programmed value of  $f_{OSC}$ . If a switching power supply is used to power the LTC6900, and if the ripple of the power supply is more than a few tens of millivolts, make sure the switching frequency and its harmonics are not related to the output frequency of the LTC6900. Otherwise, the oscillator may show additional frequency error.

If the LTC6900 is powered by a switching regulator and the switching frequency or its harmonics coincide with the output frequency of the LTC6900, the jitter of the oscillator output may be affected. This phenomenon will become noticeable if the switching regulator exhibits ripples beyond 30mV.

### START-UP TIME

The start-up time and settling time to within 1% of the final value can be estimated by  $t_{START} \cong R_{SET}(3.7\mu s/k\Omega) + 10\mu s$ . Note the start-up time depends on  $R_{SET}$  and it is independent from the setting of the divider pin. For instance with  $R_{SET} = 100k$ , the LTC6900 will settle with 1% of its 200kHz final value ( $N = 10$ ) in approximately 380 $\mu s$ . Figure 6 shows start-up times for various  $R_{SET}$  resistors.

Figure 7 shows an application where a second set resistor  $R_{SET2}$  is connected in parallel with set resistor  $R_{SET1}$  via switch S1. When switch S1 is open, the output frequency of the LTC6900 depends on the value of the resistor  $R_{SET1}$ . When switch S1 is closed, the output frequency of the LTC6900 depends on the value of the parallel combination of  $R_{SET1}$  and  $R_{SET2}$ .

The start-up time and settling time of the LTC6900 with switch S1 open (or closed) is described by  $t_{START}$  shown above. Once the LTC6900 starts and settles, and switch S1 closes (or opens), the LTC6900 will settle to its new output frequency within approximately 70 $\mu s$ .

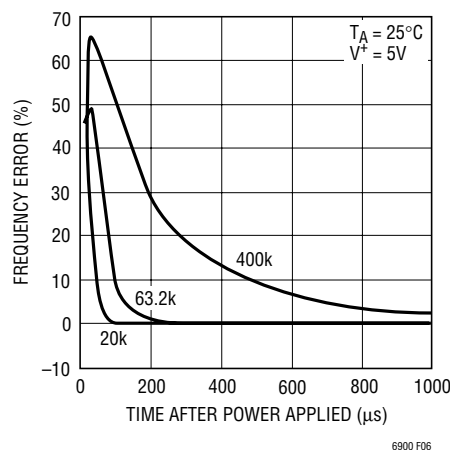

Figure 6. Start-Up Time

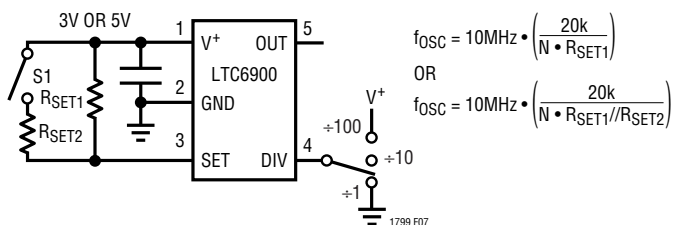

Figure 7



## APPLICATIONS INFORMATION

### Jitter

The typical jitter is listed in the Electrical Characteristics . These specifications assume that the capacitance on SET (Pin 3) is limited to less than 10pF, as suggested in the Pin

Functions description. If this requirement is not met, the jitter will increase. For more information, contact Linear Technology Applications group.

## PACKAGE DESCRIPTION

**S5 Package**  
**5-Lead Plastic SOT-23**  
 (Reference LTC DWG # 05-08-1635)

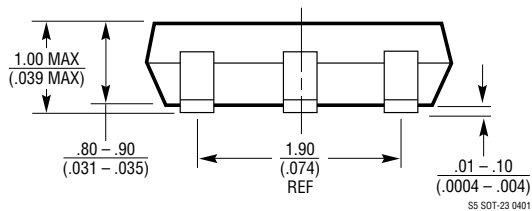
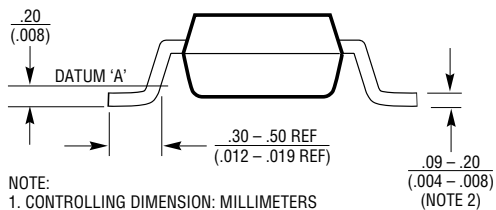
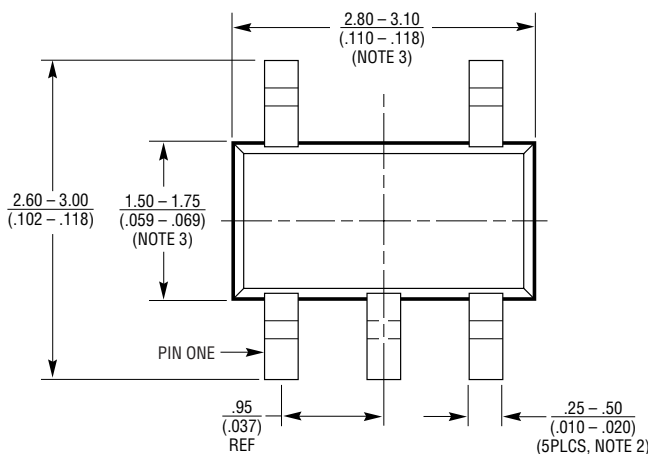

- NOTE:
1. CONTROLLING DIMENSION: MILLIMETERS
  2. DIMENSIONS ARE IN  $\frac{\text{MILLIMETERS}}{\text{INCHES}}$
  3. DRAWING NOT TO SCALE
  4. DIMENSIONS ARE INCLUSIVE OF PLATING
  5. DIMENSIONS ARE EXCLUSIVE OF MOLD FLASH AND METAL BURR
  6. MOLD FLASH SHALL NOT EXCEED .254mm
  7. PACKAGE EIAJ REFERENCE IS:  
 SC-74A (EIAJ) FOR ORIGINAL  
 JEDEC MO-193 FOR THIN

## RELATED PARTS

PART NUMBER	DESCRIPTION	COMMENTS
LTC1799	1kHz to 30MHz ThinSOT Oscillator	Identical Pinout, Higher Frequency Operation